

ELECTRONIC INSTABILITY COMPENSTATION FOR SURVEILLANCE SENSOR SET IN MINIATURE UAV

Wojciech Komorniczak, Tomasz Górski, Adam Kawalec, Jerzy Pietrasiniński

Military University of Technology, Faculty of Electronics, Institute of Radioelectronics, Gen. Kaliskiego 2, 00-908 Warszawa
(✉ w.komorniczak@wel.wat.edu.pl, +48 22 683 7408, tgorski@wat.edu.pl, adam.kawalec@wel.wat.edu.pl, jerzy.pietrasinski@wel.wat.edu.pl)

Abstract

The paper presents an idea of the surveillance sensor set on-board a miniature Unmanned Aerial Vehicle (UAV). Because of the strong influence of the atmospheric conditions (winds, thermals, air movements in general) on the airplane behaviour, there is a need for platform stabilization. It is required in order to make use of the sensors in actual operation. In the presented paper the synthetic aperture radar (SAR) is considered to be the most important as well as the most demanding sensor. Two methods of platform stabilization are shown and discussed: the hybrid (electro-mechanical) method and electronic compensation method.

Keywords: instability compensation, inertial sensors, autonomous flying platform, UAV, SAR.

© 2009 Polish Academy of Sciences. All rights reserved

1. Introduction

In the last years miniature Unmanned Air Vehicles (UAVs) gain more and more attention. This is caused by the growing requirement of obtaining reliable unmanned surveillance in order to reduce human loss in the battlefield. On the other hand it is important to be equipped with a system that is relatively cheap. In Table 1 we can see advantages and disadvantages of mini UAVs.

Table 1. Advantages and disadvantages of mini UAVs.

advantages	disadvantages
low cost	low payload
simple logistics	pervious to air movements
can replace manned planes	short flight time
no human loss	low range
flying low and slow	flying low and slow

Low cost and no human loss are very important features of mini UAVs [1]. On the other hand we have a relatively low payload and problems with stabilization. Because of the small load and narrow flight speed envelope, the platform is experiencing high instabilities caused by atmospheric movements [6].

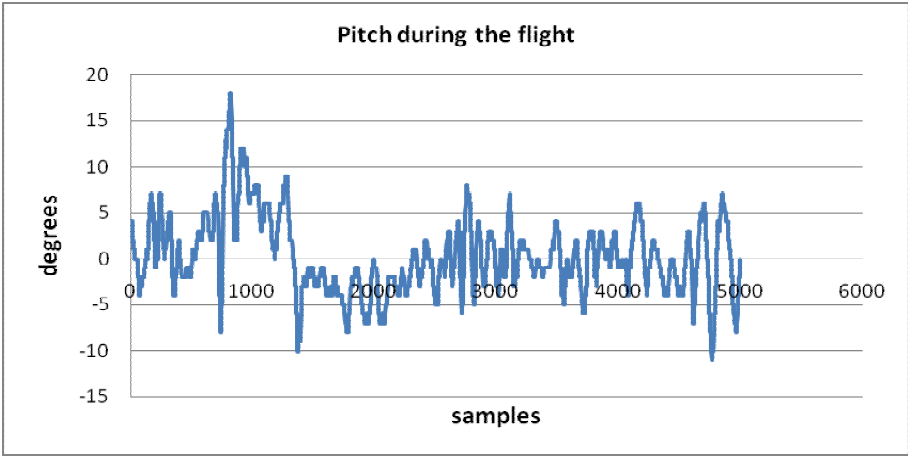

Fig. 1. Pitch during the flight mission.

In Fig. 1 we can see instabilities in pitch during the flight mission. It is evident that such instabilities (up to 20 degrees) can cause problems in surveillance [2]. For example a typical observation angle of modern cameras varies from single degrees up to 40 degrees. This means that, because of pitch variations, it is impossible to have a target within the observation field uninterruptedly. We can encounter a similar situation with roll.

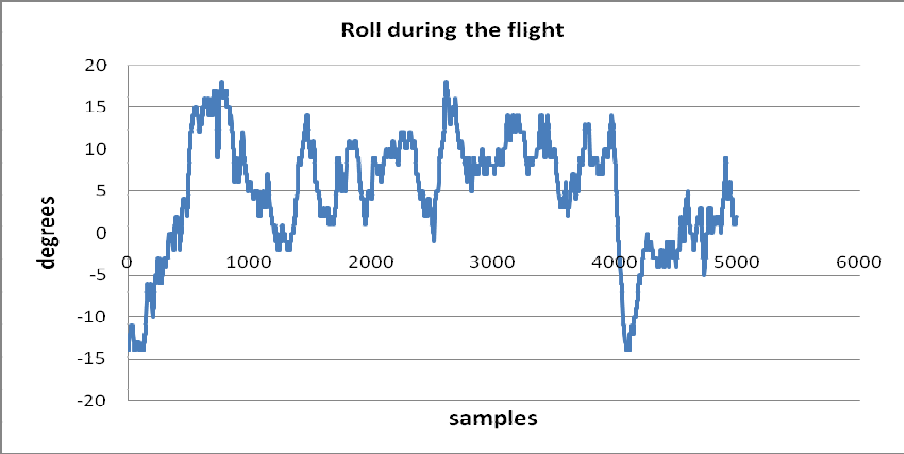

Fig. 2. Roll during the flight mission.

In Fig. 2 we can see roll during a circular flight. It is clear that apart from offset that is needed to maintain circular flight, we have strong oscillations. We want to stress that such oscillations are present even with an auto-pilot system that is designed to maintain airplane attitude and flight parameters. An additional problem will be present with Synthetic Aperture Radar (SAR), where velocity instabilities are important. In Fig. 3 we can see the velocity during the flight. It is clear that changes in velocity are considerably high.

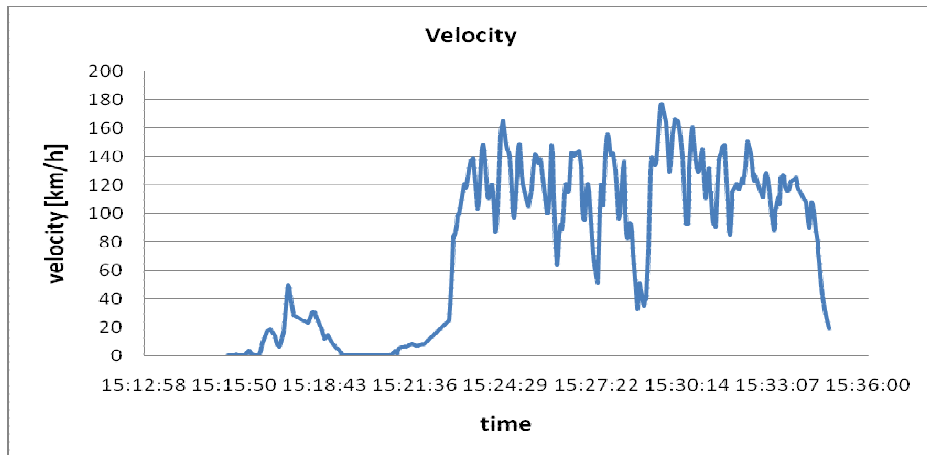

Fig. 3. Velocity during the flight mission.

2. Concept of dual stabilization

Because of oscillations mentioned before, it is necessary to design a stabilization unit. In our opinion it is impossible to compensate oscillations perfectly using only a stabilized observation head. Therefore we want to present the concept of combining electro-mechanical stabilization and an Attitude and Heading Reference System (AHRS) for purely algorithmic stabilization. It is important to understand what type of oscillations can be eliminated by both systems. We can categorize instabilities into trajectory, speed and attitude instabilities [5]. The electro-mechanical system that we design, can eliminate a great part of attitude instabilities (pitch, roll and yaw). It cannot eliminate trajectory and speed instabilities. On the other hand, data from AHRS can be helpful in compensating attitude and speed instabilities. In Fig. 4 we can see an aircraft that will be used to test stabilization systems.

There is no available publication related to the stabilization of a miniature UAV flying platform in order to host a SAR radar the way it was proposed in the article. Some of the companies (like ImSar, USA with the NanoSAR radar) claim to use a similar solution. The strictly military application of such an approach seems to be the explanation of that situation.

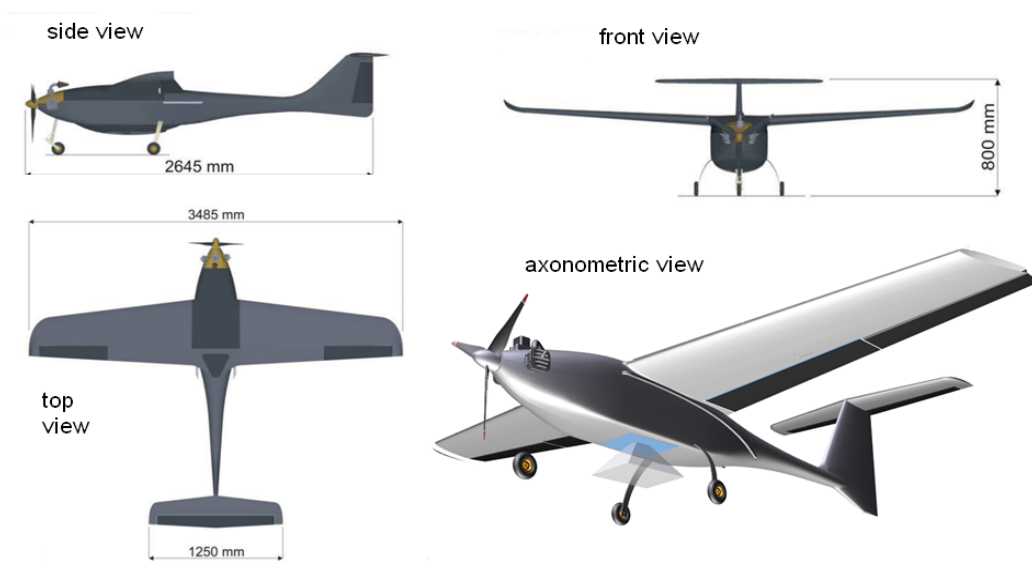

Fig. 4. Mini UAV.

This aircraft is a high wing (self stabilizing design) equipped with a gas-powered motor. In the bottom part of the aircraft a mounting point for a stabilizing platform will be placed.

An electromechanical stabilization unit (Fig. 5) is designed to compensate oscillations of high amplitude (up to tens of degrees) and low angular velocity (up to 60 degrees per second). A distinctive feature of this solution is the fact that all rotation axes have a single midpoint in the centre of mass of the aircraft. This allows to avoid coupling between stabilization actions of the electromechanical unit and platform movements.

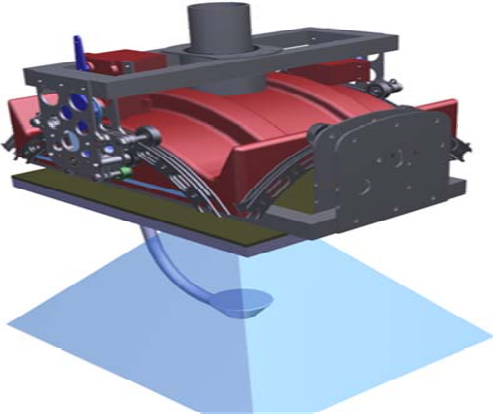

Fig. 5. Electromechanical stabilization unit.

The electromechanical stabilization unit is equipped with three-channel circuits responsible for pitch, roll and yaw stabilization. Each channel uses a piezoelectric gyroscope and rate gyro. The processing unit is using a Proportional-Integral-Differential (PID) loop to achieve the stabilization effect for each channel separately. The steering loop is implemented in an ARM7 processor. High angular velocity oscillations cannot be compensated by the electromechanical unit. It is caused by the unit's inertia. Therefore it is necessary to have another system of compensation [7, 8].

3. Electronic compensation.

Low amplitude and high angular velocity oscillations can be compensated using an AHRS unit. Data from the AHRS can be used by the compensation algorithm. This algorithm is sensor-specific. We focused our effort to improve SAR imaging. Our goal is to supply the SAR algorithm with data from the AHRS system to compensate flight instabilities (Fig. 6).

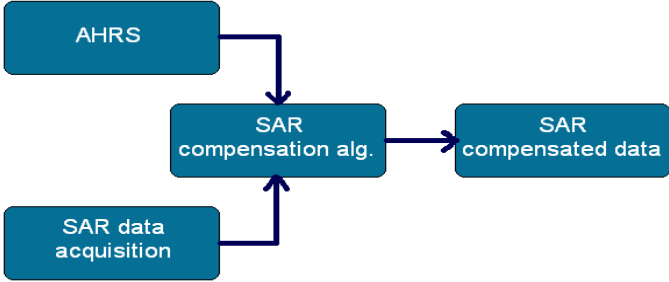

Fig. 6. SAR data compensation.

The designed AHRS system uses 13 sensors (inertial and absolute) – Fig. 7.

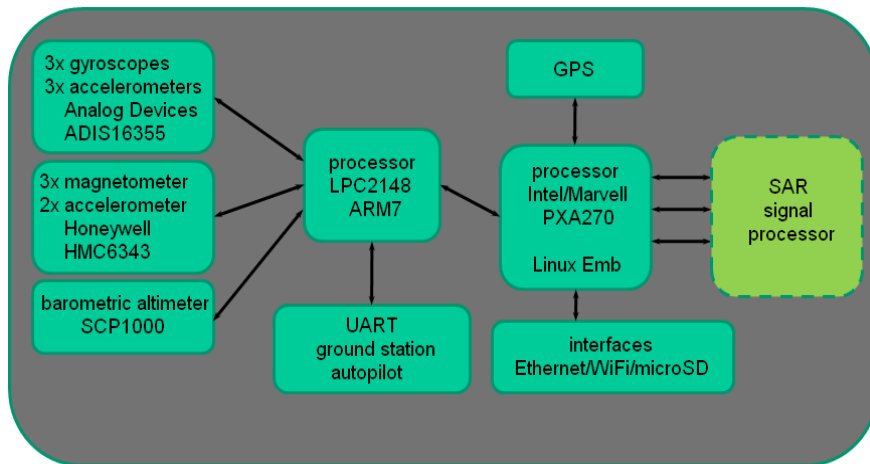

Fig. 7. AHRS unit design [4].

Data fusion from sensors is based on the Kalman filter. It gives Euler angles for each (of three) axis with the update frequency up to 500 Hz [3, 9]. This unit is time-drift compensated and can achieve very high short-term accuracy.

This unit can be particularly helpful for SAR (Synthetic Aperture Radar) imaging. In order to produce a single image pixel, SAR is processing multiple pulses. After recording in the computer memory, pulses are batch processed. SAR image processing is called focusing and can be decomposed into two separate algorithms: range compression and azimuth compression. Sometimes between range and azimuth compression there is a need to apply additional processing – range migration compensation. SAR processing is relatively simple in the case of straight-line flight path, constant velocity of the platform and constant orientation of the system. These assumptions are difficult to achieve, and in fact are only viable for spaceborne systems. In the case of airborne systems, platform oscillations have a very strong, negative effect. This is particularly true for mini UAVs. We can distinguish three types of errors in SAR systems caused by platform instabilities: trajectory deviations, velocity error and attitude error. Attitude error causes angular movement of the antenna and the antenna beam. Its effect is shortening of synthetic aperture and problems with the focusing algorithm.

The electromechanical unit can compensate this error. In more advanced systems the same compensation can be achieved using an array antenna and beam forming. In such a case there is no need for a mechanical unit. Trajectory deviations and velocity errors produce a phase error to the received signal. To compensate this error we can apply some compensation algorithm based on the AHRS system or autofocus. In order to achieve this compensation it is necessary to know the trajectory and speed with an accuracy of the order of fractions of the wavelength and update frequency high enough to obtain reliable trajectory approximation. Using only GPS data is insufficient, since the accuracy is of the order of meters and the update frequency is too low (around 10 Hz). Therefore we designed an AHRS system with inertial sensors.

4. Conclusions

The flight test results presented in the paper were taken with the use of a miniature UAV without any stabilization. The results show the need of stabilization, which was described. The presented concept is in its final stage of implementation.

Acknowledgements

This work is supported by the Polish government (grant PBZ-MNiSW-DBO-04/I/2007).

References

- [1] A. Kawalec, W. Komorniczak, J. Pietrasiński, W. Czarnecki: "Evaluation of low -cost micro UAV platform for sensor suite". *International Radar Symposium IRS 2006*, Kraków, Poland, 2006, pp. 605-608.
- [2] A. Kawalec, W. Komorniczak, J. Pietrasiński: "The Instability Measurements for the Unmanned Aerial Platform as a Radar Carrier". *International Radar Symposium IRS 2008*, Wrocław, Poland, 2008, pp. 71-74.
- [3] M. Liggins, D. Hall, J. Llinas: *Multisensor Data Fusion. Theory and Practice*. CRC Press 2008.
- [4] W. Komorniczak, T. Górski, A. Kawalec, J. Pietrasiński: „Sensor set stabilization system for miniature UAV”. *Signal Processing Symposium SPS 2009*, Jachranka, Poland, 2009.
- [5] P. Batista, C. Silvestre, P. Oliveira: "Position and velocity optimal sensor-based navigation filters for UAVs Export". *American Control Conference*, 2009, pp. 5404-5409.
- [6] Ippolito, C. Al-Ali, K. Yoo-Hsiu Yeh: "Vision Aided Inertial Navigation with Measurement Delay for Fixed-Wing Unmanned Aerial Vehicle Landing Aerospace Conference". *IEEE*, 2008, pp. 1-9.
- [7] Z.J. Huang, J.C. Fang: "Integration of MEMS Inertial Sensor-Based GNC of a UAV". *International Journal of Information Technology*, vol. 11, no. 10, 2005, pp. 123-132.
- [8] T. Dang: "An iterative parameter estimation method for observation models with nonlinear constraints". *Metrol. Meas. Syst.*, vol. XV, no. 4, 2008, pp. 421-432.
- [9] J. Gajda, R. Sroka, M. Stencel, T. Zeglen: "Data fusion applications in the traffic parameters measurement". *Metrol. Meas. Syst.*, vol. VII, no. 3, 2005, pp. 249-262.